

Válvula Check Horizontal

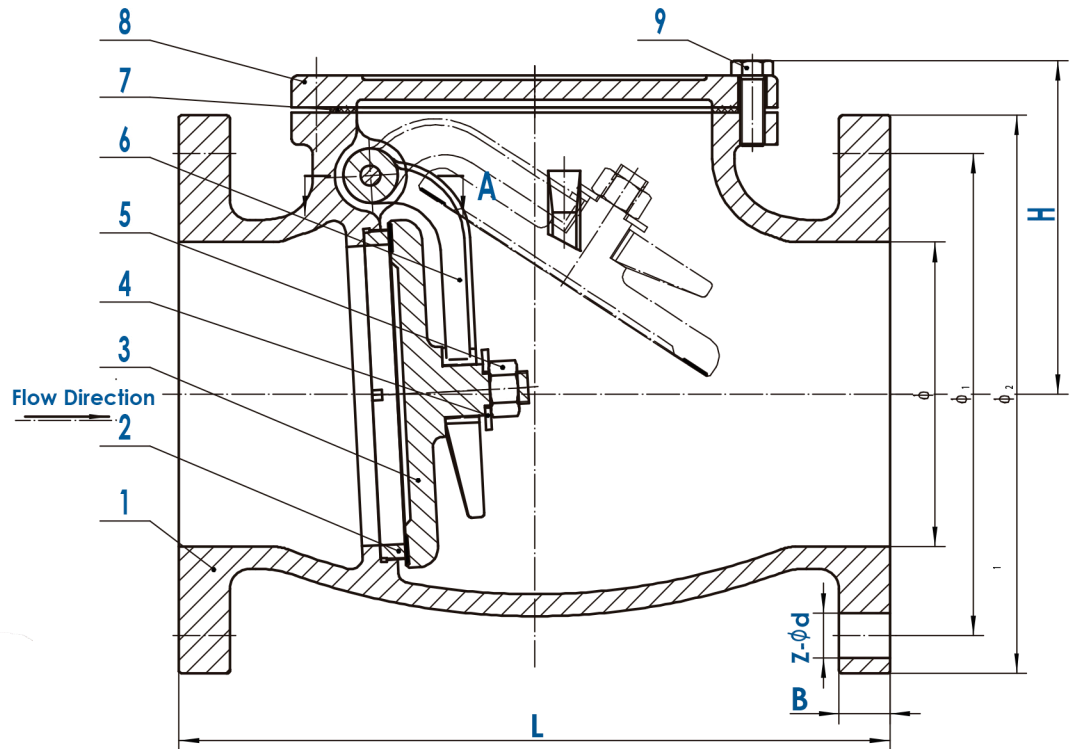

Válvula Check Horizontal

Especificaciones Técnicas		
DN	2" - 12"	
CL	150	
Suitable Temp.	-10 ~ 200°C	
Testing pressure MPa	Enclose	1.38 (water)
	Strength	2.41 (water)
Suitable Medium	Water, Vapor	

Dimension de conexión principal								
DN	ÍTEM	φ	φ ₁	φ ₂	L _o ^{+1.52}	B _o ^{+2.03}	Z-φd	H
50.8	2"	φ120.65	φ152.4	203.2	16	4-φ19.1	102	
63.5	2.5"	φ139.7	φ177.8	215.9	17.53	4-φ19.1	113	
76.2	3"	φ152.4	φ190.5	241.3	19.05	4-φ19.1	118	
101.6	4"	φ190.5	φ228.6	292.1	23.09	8-φ19.1	138	
127	5"	φ215.9	φ254	330.2	24	8-φ22.4	155	
152.4	6"	φ241.3	φ279.4	355.6	25.5	8-φ22.4	167	
203.2	8"	φ298.45	φ342.9	495.3	28.5	8-φ22.4	200.3	
254	10"	φ361.95	φ406.4	662.3	30.16	12-φ25.4	252.5	
304.8	12"	φ431.8	φ482.6		31.75	12-φ25.4	297.5	

12	Bolt	35#steel
11	Rubber pad	Neoprene
10	Cylindrical pin with internal thread	304
9	Bolt	35#steel
8	Bonnet	HT200
7	Mouth gasket	08+soft graphite
6	Arm	HT200
5	Nut	25#steel
4	Baffle	Q235
3	Disc	HT200
2	Body seal ring	Casting Brass
1	Body	HT200
No.	Part Name	Material