

# Válvula Compuerta Ext/Brida

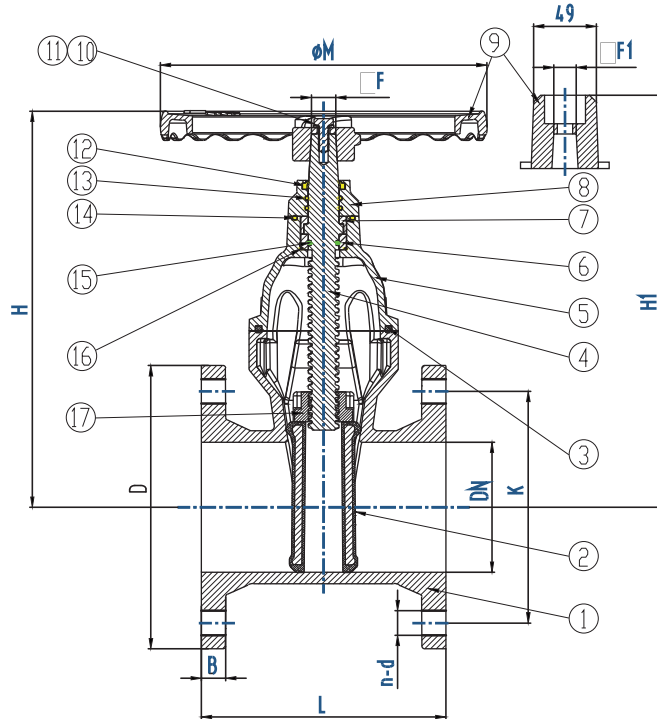

Válvula Compuerta Ext/Brida



Especificaciones técnicas		
DN	DN50-300	
NORMAS	AWWA C515 / ISO 7259	
PN	16	
Test Pressure	Streight	500 psi
	Seal up	250 psi
Medium	Clear, air	
Drive form	Handwheel / Cap	

NO	NAME	MATERIAL	STANDARD
1	Body	GGG50	ASTM A536
2	Disk	EPDM+GGG50	ASTM A536
3	Bonnet Gasket	NBR	ISO 4633
4	Stem	SS420	ASTM A959
5	Bonnet	GGG50	ASTM A536
6	Gland	GGG50	ASTM A536
7	Handwheel/Driving cap	GGG50	ASTM A537
8	Bolts	A2-70	ASTM A959
9	Washers	A2-70	ASTM A959
10	Dustring	NBR	ISO 4633
11	O Ring	NBR	ISO 4633
12	O Ring	NBR	ISO 4633
13	O Ring	NBR	ISO 4633
14	O Ring	NBR	ISO 4633

DN	OUTLINE	END FLANGE				OUTLINE mm			Swich ring number
	ANSI	ANSI				øM	H/H1	F/F1	
	L	D	K	n-d	B				
50	178	152	120,5	4-ø19	19,1	ø200	215/230	14	9
65	190	178	139,5	4-ø19	22,4	ø200	250/265	14	10
80	203	191	152,5	4-ø19	24	ø254	275/290	17	12
100	229	229	190,5	8-ø19	24	ø254	320/335	19	12
125	254	254	216	8-ø22	24	ø315	355/370	19	14,5
150	267	279	241,5	8-ø22	25,4	ø315	398/415	19	17
200	292	343	298,5	8-ø22	28,4	ø315	495/510	24	18,5
250	330	406	362	12-ø25	30	ø406	590/605	27	23
300	356	483	432	12-ø25	31,8	ø406	670/685	27	27