



Application

- Can be used to transfer clean water or other liquids similar to water in physical and chemical properties
- Suitable for lifting water from the well, sprinkling irrigation in garden, pressure boosting of running water, and supporting equipment etc.

Pump

- Stainless steel pump body
- Support under special anti-rust treatment
- Stainless steel impeller
- AISI 304 shaft
- Max. liquid temperature: +60°C
- Max. suction: +9 m

Motor

- C&U bearing
- Built-in thermal protector for single phase motor
- Insulation class: F
- Protection class: IPX4
- Max. ambient temperature: +40°C

Identification Codes

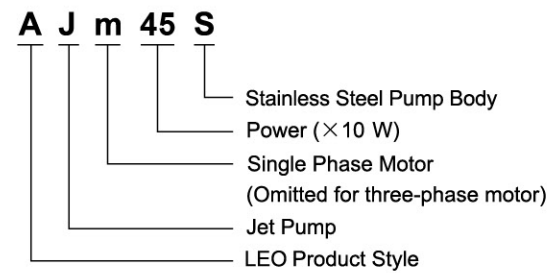

Technical Data

MODEL	POWER		Q (m³/h)	Q (l/min)															
	kW	HP		0	0.6	0.6	0.9	1.2	1.5	1.8	2.1	2.4	2.8	3.0	3.3	3.6			
AJm30S	0.3	0.4	H (m)	0	5	10	15	20	25	30	35	40	47	50	55	60			
AJm45S	0.45	0.6		30	26	23	20	18	16.5	15	13	11	-	-	-	-			
AJm60S	0.6	0.8		38	35	31	28	25	22	20	18	16	-	-	-	-			
AJm75S	0.75	1.0		42	37	33	30	27	25	23	21	20	18	-	-	-			
AJm90S	0.9	1.2		47	42	38	36	34	32	30	28	27	25	23	20	-			
				48	44	42	39	37	35	34	32	31	29	28	26	22			

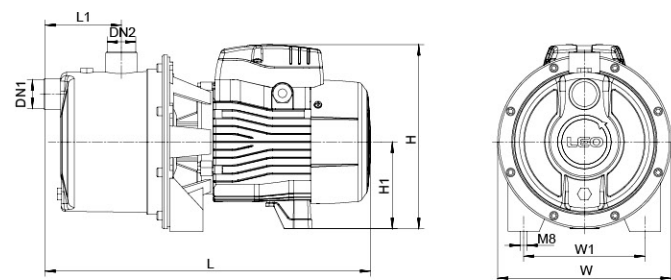

Dimension

Model	DN1	DN2	L (mm)	W (mm)	H (mm)	L ₁ (mm)	W ₁ (mm)	H ₁ (mm)
AJm30S	1"	1"	337	180	181.5	78	140	90
AJm45S			329	180	181	78	140	90
AJm60S			381	200	214	88	140	103
AJm75S			381	200	214	88	140	103
AJm90S			381	200	214	88	140	103

Hydraulic Performance Curves

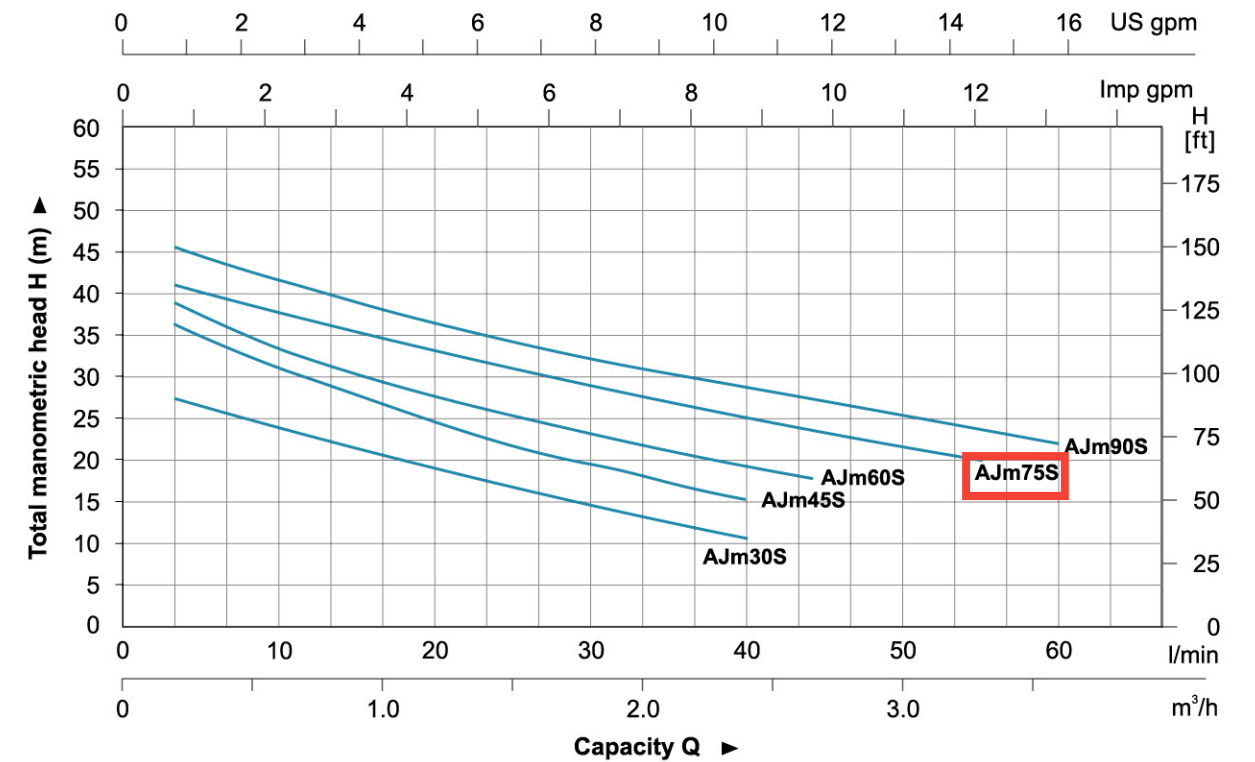

Materials Table

No.	Part	Material
1	Pump body	AISI 304
2	Venturi tube	PPO
3	Diffuser	PPO
4	Impeller	AISI 304
5	O-ring	NBR
6	Mechanical seal	Carbon/Ceramic
7	Bracket cover	AISI 304
8	Support	ZL102
9	Rotor	
10	Bearing	
11	Stator	
12	Terminal board	PC
13	Terminal box	ABS
14	Capacitor	
15	Rear cover	ZL102
16	Fan	PP
17	Fan cover	PP

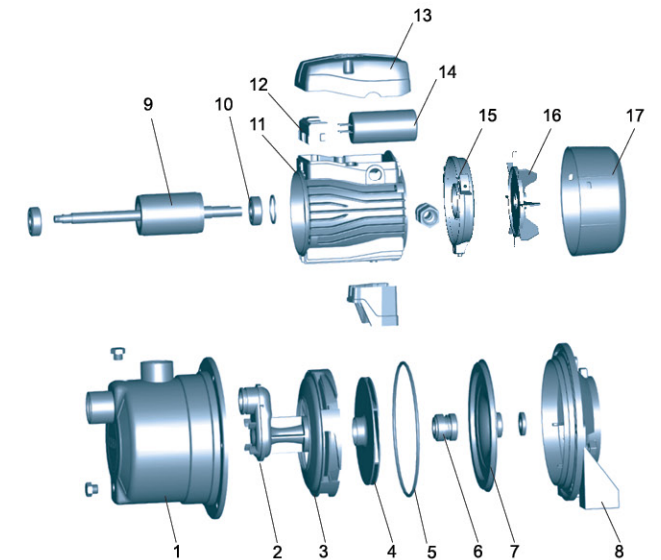

Package Information

Model	GW (Kgs)	L (mm)	W (mm)	H (mm)	Quantity (PCS/20 TEU)
AJm30S	6.0	350	180	220	1920
AJm45S	6.7	350	180	220	1920
AJm60S	9.2	420	228	257	1056
AJm75S	10.1	420	228	257	1056
AJm90S	10.7	420	228	257	1056

